



**SAFE
CORPORATION**

11, Clive Row, Room No. 11A,
Kolkata: 700001, West Bengal.

+91 9830515607 | +91 9831384631
91 - 33 - 2242 3713

safecorp1@gmail.com

FORGED GLOBE VALVES

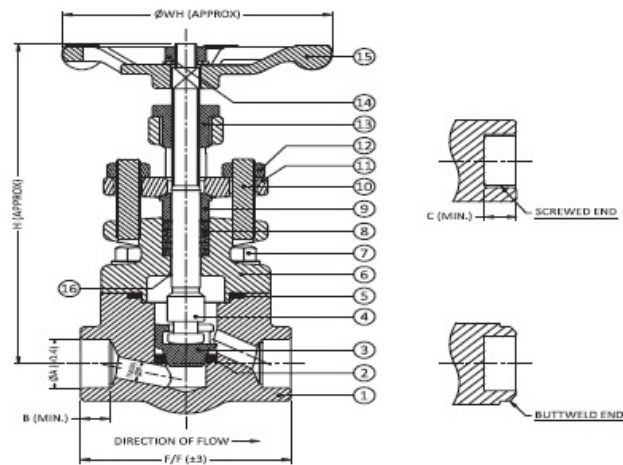

SR. No.	Part Name	Material	Qty.
1	Body	ASTM A 105/F304/F304L/F316/F316L/F 11/F22/LF2	1
2	Bonnet	ASTM A 105/F304/F304L/F316/F316L/F 11/F22/LF2	1
3	Wedge	ASTM A217 Gr. CA-15/CF8/CF8M/CF3/CF3M	1
4	Seat Ring	ASTM A276 TYPE SS-410/304/304L/316/316L	2
5	Stem	ASTM A182 Gr.F6a/F304/F304L/F316/F316L	1
6	Backseat	INTEGRAL	-
7	Gland Bush	ASTM A276 TYPE SS-410/304/304L/316/316L	1
8	Gland Packing	FLEXIBLE GRAPHITE RINGS	1
9	Stud	ASTM A193 Gr. B7/B8/B8M	2
10	Gland Flange	ASTM A105/F304/F316/F11/F22	1
11	Hex Bolt	ASTM A193 Gr. B7/B8/B8M	4
12	Gasket	SS-304 SPIRAL WOUNDED GRAPHITE	1
13	Stem Nut	ASTM A194 Gr. 2H/B8/B8M	1
14	Yoke Sleeve	EN SERIES MATERIAL	1
15	Nut	ASTM A194 Gr. 2H/B8/B8M	2
16	Hand Wheel	SG IRON	1

HYDRO TEST PRESSURE - Kg/Cm ²			
RATING	800#	1500#	
SHELL	211	390	
SEAT	153	290	
AIR TEST PRESSURE - Kg/Cm ²			
SEAT	7	7	

TECHNICAL DATA

Construction	: Out Side Screw & Yoke Type, Bolted Bonnet
Design & Mfg Std	: As Per API 602 / ISO 15761
Insp & Test Std	: As Per API 598
End Connection	: Socket Weld As Per ASME B16.11 Screwed End As Per ASME B1.20.1
Moc	: ASTM A105, F304, F304L, F316, F316L, F5, F9, F11, F22, LF2
Operation	: Handwheel / Actuator