



**SAFE  
CORPORATION**

11, Clive Row, Room No. 11A,  
Kolkata: 700001, West Bengal.

+91 9830515607 | +91 9831384631  
91 - 33 - 2242 3713

✉ safecorp1@gmail.com

## FORGED CHECK VALVES

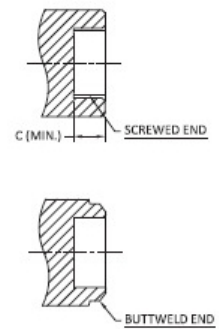
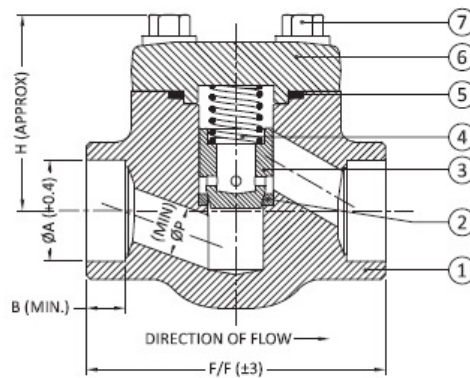

SR. No.	Part Name	Material	Qty.
1	Body	ASTM A105/F304/F304L/F316/F316L/F11/F22/LF2	1
2	Cover	ASTM A105/F304/F304L/F316/F316L/F11/F22/LF2	1
3	Plug	ASTM A276 TYPE SS-410/304/304L/316/316L	1
4	Seat Ring	ASTM A182 Gr.F6a/F304/F304L/F316/F316L	1
5	Spring	ASTM A313 Gr. SS-304/304L/316/316L	1
6	Gasket	SS-304 SPIRAL WOUNDED GRAPHITE	1
7	Hex Bolt	ASTM A193 Gr. B7/B8/B8M	4

HYDRO TEST PRESSURE - Kg/Cm <sup>2</sup>			
RATING	800#	1500#	
SHELL	211	390	
SEAT	153	290	
AIR TEST PRESSURE - Kg/Cm <sup>2</sup>			
SEAT	7	7	

### TECHNICAL DATA

Construction	: Bolted Cover
Design & Mfg Std	: As Per Api 602 / ISO 15761
Insp & Test Std	: As Per API 598
End Connection	: Socket Weld As Per ASME B16.11 Screwed End As Per ASME B1.20.1
Moc	: ASTM A105, F304, F304L, F316, F316L, F5, F9, F11, F22, LF2